





PLC based Smart Controller for PST in Al-Rustumyah Waste Water Treatment Plant

Malak A. Dawood ^{1*}, Mehdi J. Marie ², Satea H. Al-Najjar ³

¹ Department of Computer Engineering, Al-Iraqia University, Baghdad, Iraq

² Al-Zawraa State Company, Ministry of Industry and Minerals, Baghdad, Iraq

³ Department of Network and Cybersecurity Engineering, Al-Iraqia University, Baghdad, Iraq

*Corresponding Author: malak.arif93@gmail.com

Citation: Malak A. Dawood, Mehdi J. Marie, & Satea H. Al-Najjar. (2026). PLC based Smart Controller for PST in Al-Rustumyah Waste Water Treatment Plant. *Iraqi Journal of Communications and Computer Networks*, 2(1), 27–36.

ARTICLE INFO

Received: Dec. 22, 2025

Revised: Mar. 12, 2025

Accepted: Apr. 19, 2026

ABSTRACT

The ubiquitous employment of new technologies in control applications opened the era of smart control systems. In this project, the programmable logic controller (PLC) used to update the traditional (by relays) control units in the primary settling tank (PST) in the Al-Rustumyah North wastewater treatment plant (WWTP) in Baghdad city. The control methodology depended on the capabilities of the software and hardware of this industrial computer. The existing control facility used to control the process of depends on the control by the old methods. This work started firstly with comprehensive investigations of the old control philosophy designed according to the process requirements of the whole plant (WWTP). The treatment of the wastewater in this stage is very important because it may cause malfunctions in the next stages. Secondly, new hardware components had been chosen with associated software and programs had been built using DELTA systems with a human machine interfaces (HMI). The new system and enhanced control methodology reduced the power consumption to approximately 30% and the size of the board to 40%. The smart control system for this task had performed by utilizing the DELTA controller to control the whole process efficiently.

Keywords: Waste water treatment plant, Primary settling tank, DELTA PLC, Smart control systems.

INTRODUCTION

Control system is one that can manage or organize itself or any other system to achieve a particular objective or mission. The basis of the conventional theory for the design of control systems contains two primary concepts. the stability of the system, a notion of sensitivity of a transfer function. The open-loop control systems (non-feedback control systems), closed loop control systems (feedback control systems) are the two primary kinds of concerned control systems. The control action in an open-loop control system is really only subject on the input signal and does not rely on the output response. While the closed-loop system is one that contains feedback and may self-correct in response to a variety of changes [1,2].

The PLCs are currently the most extensively used industrial process smart control technology, regarded as an industrial-grade computer that can be programmed to perform control functions. Many of the hard wires associated with relay classic control circuits are eliminated with the programmable controller. PLCs are control systems that used to automate electromechanical and chemical processes in factories and industries. Automated control systems were utilized to maintain the desired value of a measured or estimated process quantity (controlled variables) within prescribed limits (errors or deviation) without the direct intervention of the operator. Through the twentieth century, it has evolved from simple sequential control to complicated electronics systems. Manufacturing automation and process plant automation systems are the two categories of industrial automation systems. The essential meanings of the notions of automated control and industrial automation are different. Automatic control is the continuous control of a physical analog variable via any sort of actuator, whereas industrial automation is the digital or sequential ON-OFF control of a two-state device[3,4].

Nowadays, PLC is widely utilized in digital world applications in the industrial sector. They are typically employed in the industrial sphere to control a mechanical motion, such as that of a machine or a heavy machine, for efficient production. It may demonstrated the modernization of this traditional system by designing a control panel with command components such as relays and a PLC to run the programs that control and monitor the system. Technologies have focused on the design and implementation of a PLC-based water level control system ultimately. The water level indicator circuit design, manual water level control system, and PLC based automatic water level control are the three key aims of this research. Also, they have provided a system for treating a wastewater stream that produces an effluent stream a treatment system can include a sensor for measuring a characteristic of the wastewater stream and/or the effluent stream, a pump for supplying a chemical additive to the wastewater stream, and a controller for varying the flow rate of the chemical additive based on real-time analysis of measurements generated by the sensor [5, 6]. A typical system that can depict the smart industrial control used PLCs facility is shown in Figure (1).

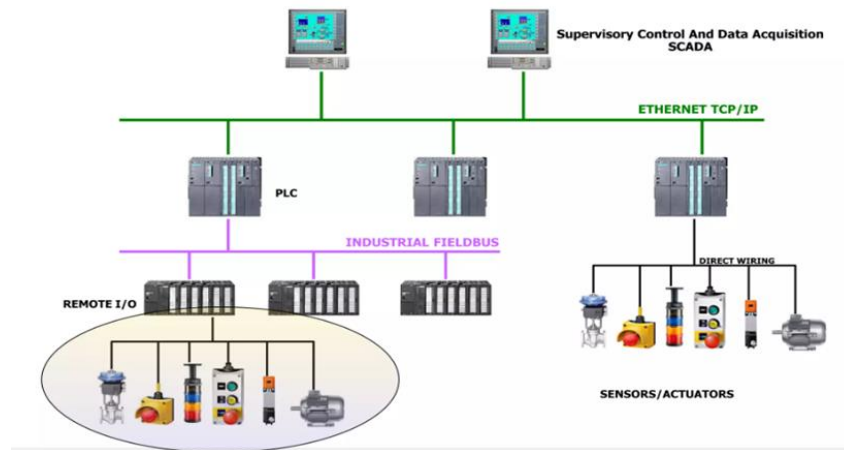

Figure (1).Basic kinds of industrial-type equipment composing an industrial system [7]

LITERATURE REVIEW

PRIMARY SETTLING TANK

The PST is an integral section of the entire wastewater treatment process, sludge treatment, and digester as shown in Figure (2). They are used to remove solids from wastewater treatment plants and are regarded as the most critical component of the biological and sludge treatment processes. The purpose of wastewater treatment is to speed up the natural purification processes [9]. There are two basic stages in the treatment of wastes, primary and secondary. In the primary stage, solids are allowed to settle and be removed from wastewater. The secondary stage uses biological processes to further purify wastewater as shown in Figure (3). That What has mentioned earlier is the sedimentation basin for heavy water purification for the second stage of the Northern Rustumiya sewerage project, which has 12 basins within the project, so this stage is considered one of the most important stages of heavy water purification [10,11]. Inside the project because heavy water in this stage is the most difficult as it is the first stage of filtering (where the first stage is limited to transporting heavy water from the bottom to the top) because it contains large quantities of waste and solids in addition to oils of various kinds that cause damage to the filter tanks Through H₂s emissions that lead to iron oxidation in the aquarium and electrical system [12, 13].

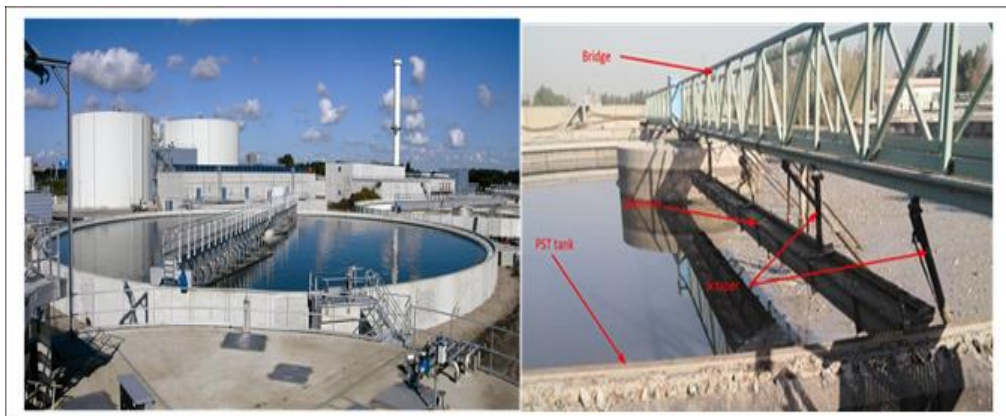
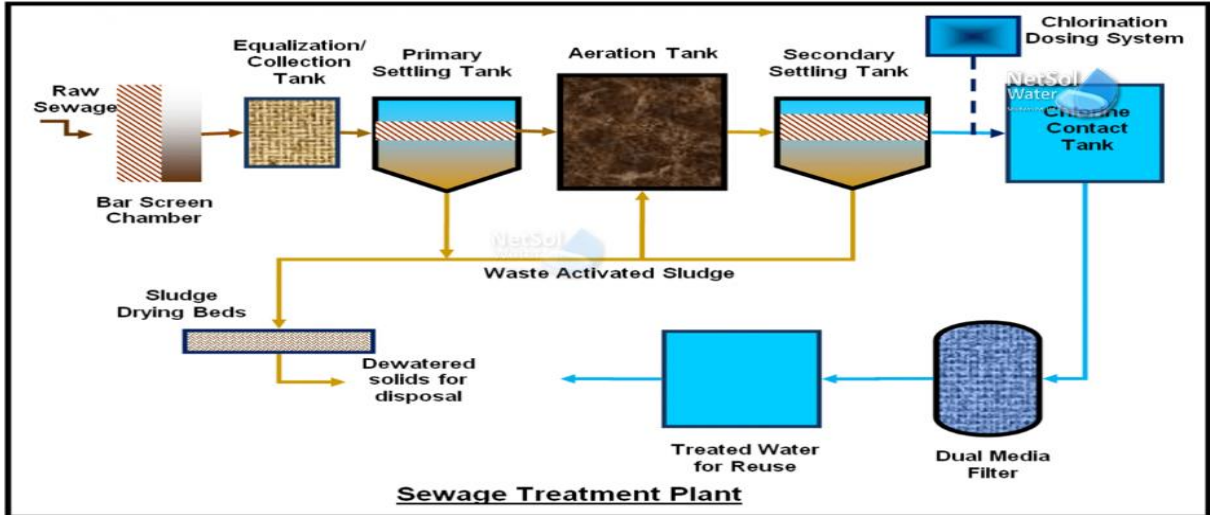

Figure (2). PST in AlRustumyah North WWTP [8]



Figure(3) Primary and secondary treatment of sewage [14].

PST SMART CONTROL

Now it is the time to articulate the PST as a popular primary treatment process existing after the screens and detarator and before aerator stage, the primary sludge is permitting to settle to the bottom of the tank, and collected by a rotating scrapper. A desludging pump is interrupt turned on to send the sludge from the blanket to the next step of the treatment. In most cases, the desludging of the PST starts and ends based on a timer, which can lead to non-optimum operating conditions. As the load to the PST is impacted by various factors such as the time (day/night) the seasonality and the rainfalls, setting the optimum timer for each PST to allow for only thick enough sludge to be sent to the thickeners has been proven to be challenging [12].The research work with ideas gathered in above steps by adopting any of below suitable approaches [6]:

A. Digital Control Philosophy [15,16]

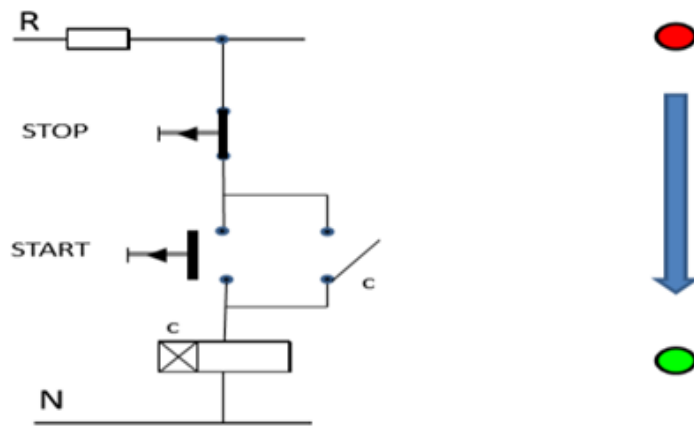

Figure(4). Latch principal for industrial control [15]

The control philosophy which is implemented in such controllers (industrial) depends on a principal called (latch principle). A coil is operated by START pushbutton (green) and stopped by STOP pushbutton (red). It is depicted as shown in Figure (4).The operation of the coil C can be represented by $C=STOP*(START + C)$, the digital control principals and state diagrams for smart control systems used by smart PLC can be formulated as below

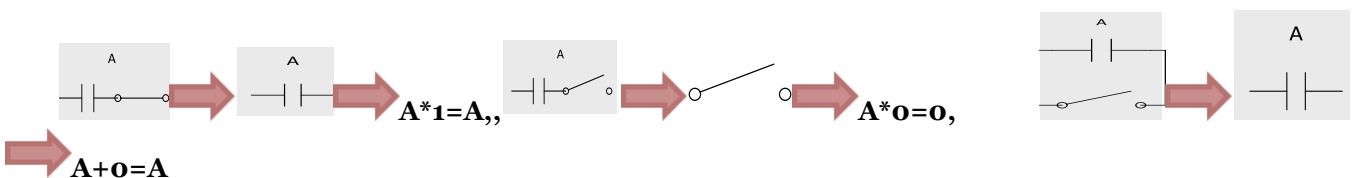

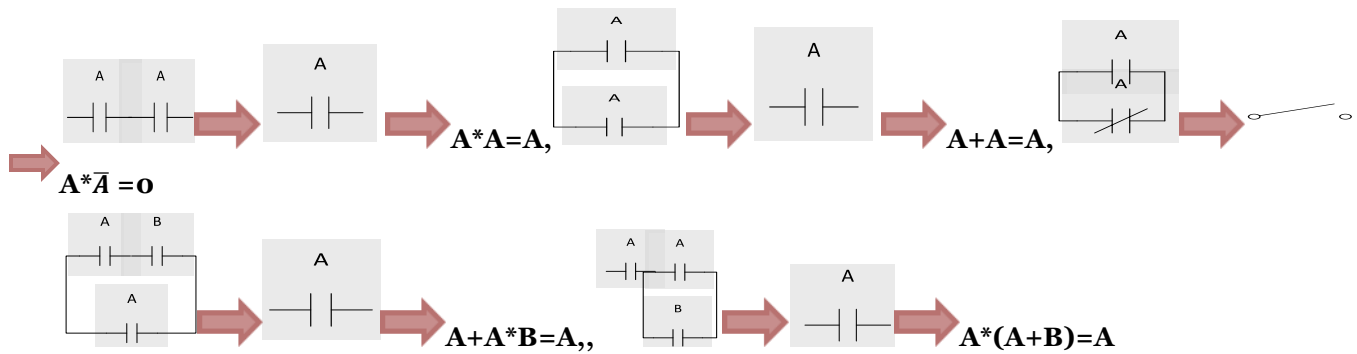

B. Use of State Diagrams

The state diagrams are used widely for smart PLC programming is pictured in Figure (5). They can be formulated by the expressions such $C1 = \bar{b}0 + c2 * (b1+c1) = \bar{b}0 * c2 * (b1+c1)$ for C1 first control relay and $C2 = \bar{C1} * (S+C2)$ for a second one. When the SWITCH ON automation circuit for a variable contains sensor contacts that are providing a non instant switch on (like a push button command) but give a signal ON as long as the signal exists then the present state is introduced [17].

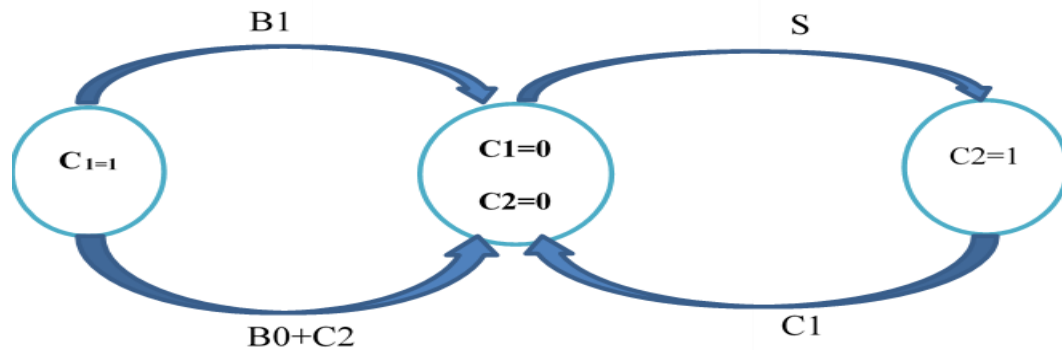

Figure (5). Picturized diagram represent the state of PLC operation [18]

METHODOLOGY

SYSTEM DESIGN AND IMPLEMENTATION

As mentioned earlier, the main goal of this work is to design and implement of a PLC based Controller for PST in AlRustumyah North Waste Water Treatment Plant . This system helps to control the PST automatically and manually using (PLC) to save time and cost. This section includes two parts, the first will demonstrate the preparation phase of the project : this phase includes the study of the old plants for the northern Rustumiyah project in terms of number limit switch, contactor , auxiliary relay , overload, push buttons... etc., to determine the number of units needed to install the new system. The second part will demonstrate the implementation stage: This stage focusing on inspecting every part in the old control system and converting it from manual control to self-control through programming the old schemes by using wpl soft software to program the diagrams in delta plc software.,As a result of the old system and its frequent malfunctions resulting from aging of relays and consumption of most of its contacts, it became necessary to think of a radical solution to all these problems, so the opinion is to use smart PLC which can be considered as an industrial computer that has the ability to control the process of PST, control and protection and assist operators in controlling the process in different units. In this project, we will design a new DELTA-type smart PLC-based control system and associated training kit for the primary sedimentation tank in the Rustumiya wastewater treatment plant of the Baghdad municipality. The old control system relied on control via relays, so it would be a great evidence for this system's implementation. one of the most important problems that occurred at the beginning of the project is understanding smart PLC system, how to program the PLC system , PLC connections, and learn PLC system with great accuracy before starting project work and learn how to connect input and output ports of PLC to a simulation I/O (input/output) panel, Understanding the integration of PLC and the connection of input / output based on the real situation in AlRustumyah. There was a problem at the beginning of the project study relating the problem statement and test criteria to ladder logic which determines the blocks to use to get the desired solution, specifying the objective. The

main objective of the project will help improve the daily operations of the filtration plant. To save time on a regular basis and reduce faults with automatic control. Show the difference between manual human control and automatic control via PLC. For which very promising results were obtained. We will use to solve this aforementioned problem by designing a control panel that contains PLC and HMI, which provides ease of access and control in the system, and WPLSOFT 2.50 is used for programming PLC in logic programming language and uses DOP SOFT to design the HMI screen, which provides ease of access and control in the system. The following points were considered in the beginning of the project simulations:

Linking the Design, after selecting the software employed for the structure of the system. The system has linked and configured to be ready for testing to give the results that are supposed to be concerned.

Implementation, after the most appropriate design has been built, the structure is implemented to be ready for the performance, which is extracted results.

Evaluation, it is the last step in which the results are evaluated and done. At this stage, the results of the proposed system will be presented.

MODELING OF PROGRAMS

The software programs are transferred to mathematical equations

$$T6 = \begin{cases} X0 = ON \rightarrow T6 = ON \\ X0 = OFF \text{ and } T6 = ON \rightarrow M6 \text{ keep on from} \\ T6 = 0 \text{ to } T6 = 5 \end{cases} \quad (1)$$

$$M11 = M13 * X3 \quad (2)$$

$$Y4 = M13 \quad (3)$$

$$C12 = \begin{cases} M6 = ON \text{ and } m13 = ON \rightarrow C12 = C12 + 1 \\ M6 = OFF \rightarrow C12 = C12 \\ C12 = K5 \rightarrow C12 = ON \end{cases} \quad (4)$$

$$T10 = \begin{cases} X2 = ON \text{ and } M11 = OFF \rightarrow T9 = ON \\ X2 = off \text{ and } T10 = ON \rightarrow M10 \text{ keep ON from} \\ T10 = 0 \text{ to } T10 = 1000 \end{cases} \quad (5)$$

$$T9 = \begin{cases} M9 = ON \rightarrow T9 = ON \\ M9 = off \text{ and } T9 = ON \rightarrow M9 \text{ keep on} \\ \text{from } T9 = 0 \text{ to } T9 = 5 \end{cases} \quad (6)$$

$$T9 = \begin{cases} M9 = ON \text{ or } C12 = ON \text{ and } T15 = ON \rightarrow T9 = ON \\ M9 = off \text{ and } T9 = ON \rightarrow M9 \text{ keep on} \\ \text{from } T9 = 0 \text{ to } T9 = 5 \end{cases} \quad (7)$$

$$M13 = (\overline{M9} * M13) + (T30 * X4) \quad (8)$$

$$T15 = \begin{cases} C12 = ON \text{ and } T15 = off \text{ and } T15 = 300 \rightarrow T15 = ON \\ C12 = off \rightarrow T15 = off \end{cases} \quad (9)$$

$$T16 = \begin{cases} C12 = ON \text{ and } T15 = off \text{ and } (M10 = ON \text{ or } x1 = ON) \\ \text{and } T14 = 300 \rightarrow T14 = ON \\ C12 = off \rightarrow T14 = off \end{cases} \quad (10)$$

$$T30 = \begin{cases} D0 = 0 \text{ and } T31 = off \text{ and } T30 < 10 \\ D0 \neq 0 \text{ or } T31 = on \text{ or } T32 = ON \text{ or } T30 < 10 \end{cases} \quad (11)$$

$$T31 = \begin{cases} D0 = 0 \text{ and } T30 = off \text{ and } T32 = off \text{ and } T31 < 10 \\ D0 \neq 0 \text{ or } T30 = on \text{ or } T32 = on \text{ or } T31 < 10 \end{cases} \quad (12)$$

$$T32 = \begin{cases} D0 = 0 \text{ and } T31 = off \text{ and } T30 = off \text{ and } T32 < 10 \\ D0 \neq 0 \text{ or } T31 = on \text{ or } T30 = on \text{ or } T32 < 10 \end{cases} \quad (13)$$

$$Y0 = (X5 * X6 * T30 * M13 * \overline{C12} * \overline{Y3} * X11) + T31 * (M44 + \overline{X0}) + T32 * (\overline{M43} * M44) + Y0 \quad (14)$$

$$Y1 = X7 * (T30 * \overline{T14} * \overline{M11}) + ((T31 + T32) * \overline{M45} * \overline{M47} * (Y1 + M46) * X2 * \overline{Y2}) \quad (15)$$

$$Y2 = T30 * T14 + ((T31 + T32) * \overline{M45} * \overline{M46} * (Y2 + M47) * X1 * \overline{Y1}) \quad (16)$$

$$Y3 = X10 * (T30 * Y4 * C12 * (M11 + Y3) * (X1 + M10) + ((T31 + T32)$$

$$*\overline{M48}*(M49+Y3)) \tag{17}$$

$$D1 = \begin{cases} \overline{X11} * \overline{X12} * \overline{X13}, = ON \rightarrow D1 = 0 \\ X11 * \overline{X12} * \overline{X13}, = ON \rightarrow D1 = 1 \\ X11 * X12 * \overline{X13}, = ON \rightarrow D1 = 2 \\ X11 * X12 * X13, = ON \rightarrow D1 = 3 \end{cases} \tag{18}$$

Ladder programming language for control system can be represented by the following circuits:

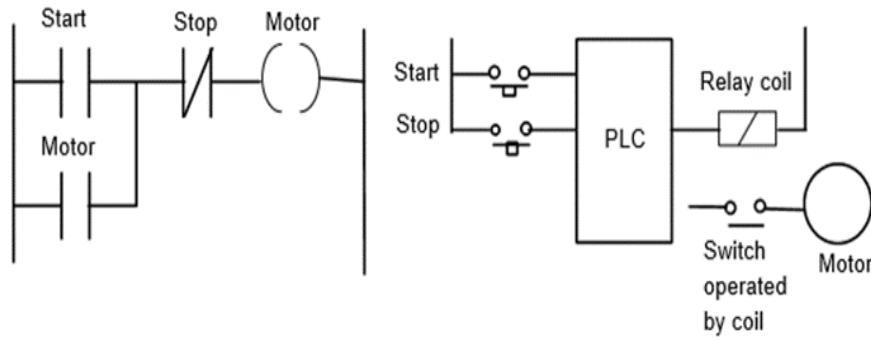

(a) [15]

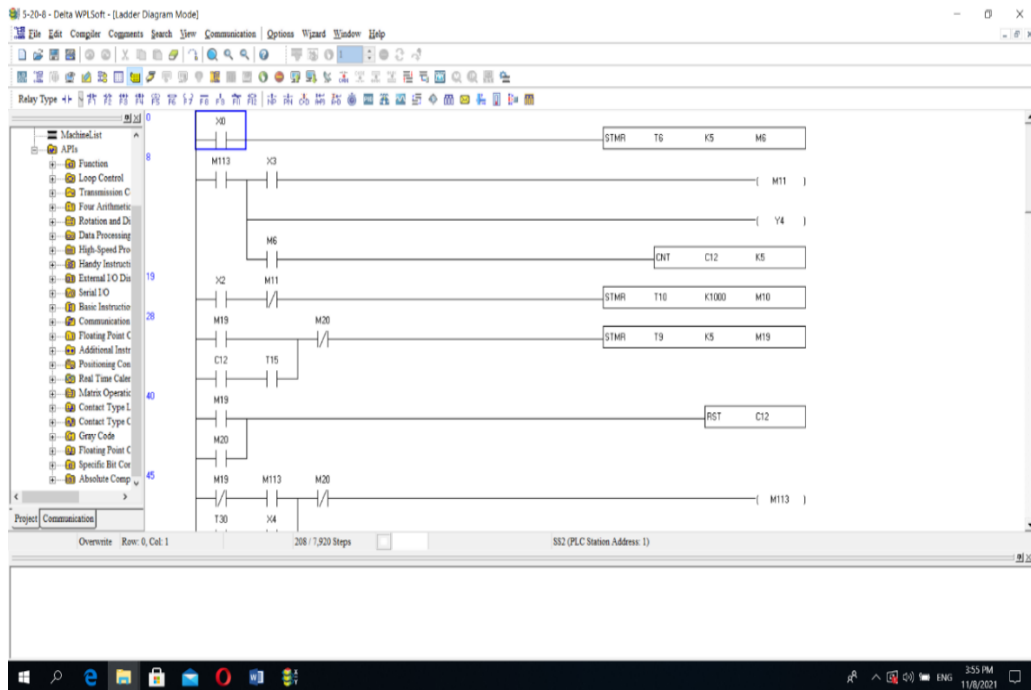

(b)

Figure (6) : (a) general view of both schemes (b) ladder programming language for control system to control motors

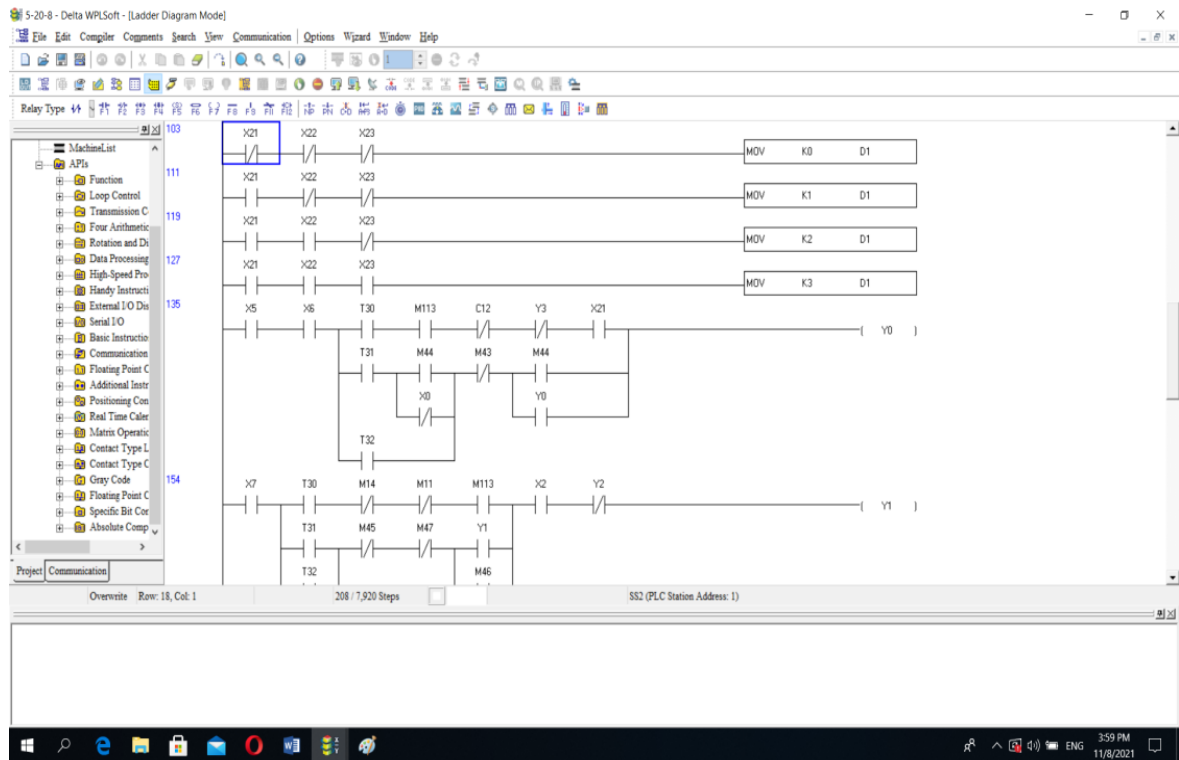

Figure (7) Ladder programming language for control system to control skimmarce

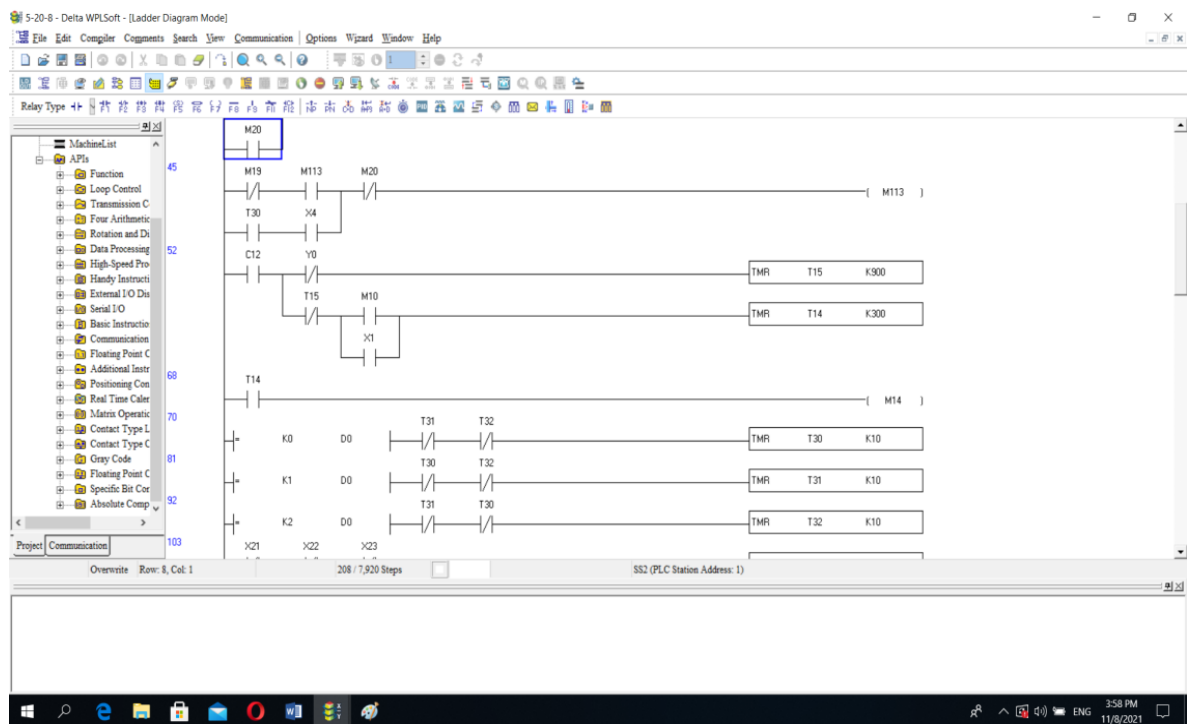

Figure (8) Ladder programming language for control system to control piston above and below states

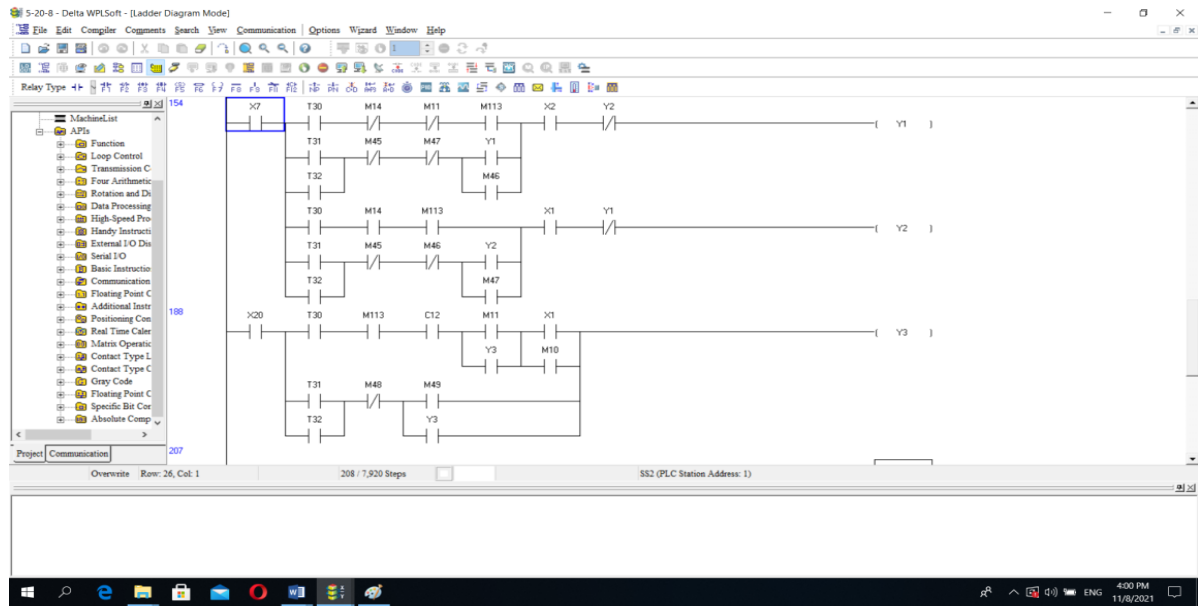
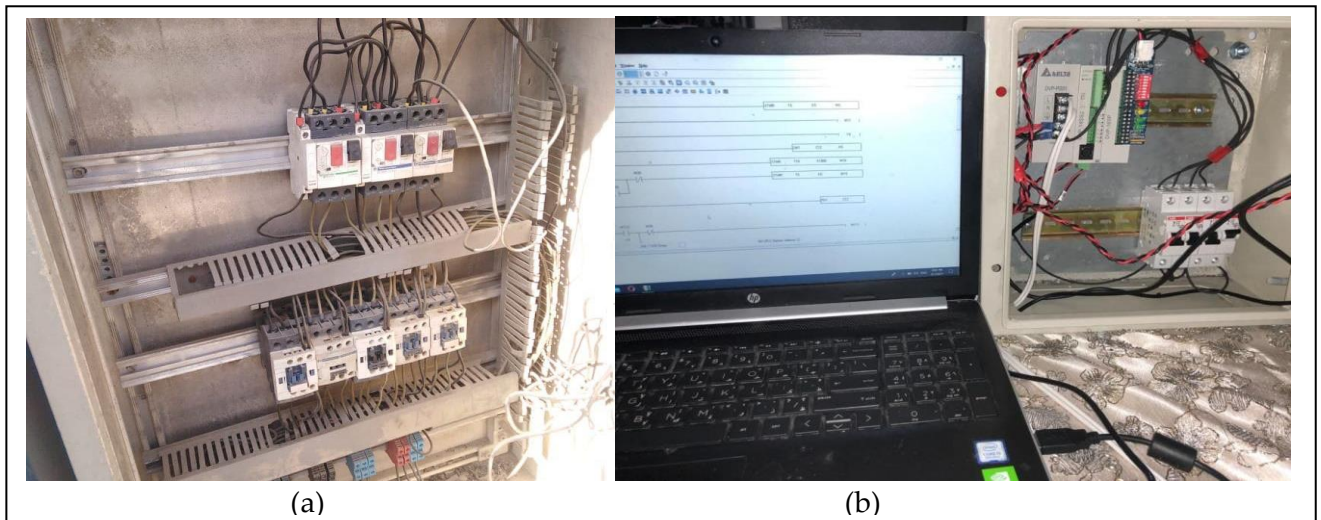

Figure (9) Ladder programming language for control system



Figure(10) (a) Old control unit of the PST (b) New smart control system (Implement of the project)

The old control strategy of the PST had been implemented through the board of Figure(10), it had been reduced to cope with the requirements of the minimum control. Since it contains large quantities of waste and solids in addition to oils of various kinds that cause damage to the filter tanks Through H₂s emissions that lead to iron oxidation in the aquarium and electrical system.

RESULTS AND DISCUSSION

The use of smart PLC for controlling the PST is approached to be very active in this project, the Delta PLC is used to implement the process control system in WWTP. It started by understanding the specific process through wiring diagrams and previous experience of the operators and the results were successfully implemented. Recently, industries requires a controller that is intelligent, smooth, and simple to operate. This becomes highly costly if the change is constantly required. Because relays are mechanical devices, their life is limited, necessitating rigorous adherence to maintenance schedules. Troubleshooting was also time-consuming due to a large number of relays and electromechanical components involved. They would be individually connected in such a way that the required control strategy is obtained. The current difficulty in modeling and controlling is complicated and interconnected contemporary systems like traffic management, chemical process, and robotic systems. Smart PLCs are utilized in virtually every side to grow and improve production needs. Whereas traditional automated systems require a large number of electromechanical relays, they may program a single PLC to do the same function. It stores instructions and performs operations like on/off control, timing, counting,

sequencing, arithmetic, and data handling using a programmable memory. The functionality of smart PLCs has expanded to encompass features beyond traditional relay control. The PLC's functions have been expanded to include process control, advanced motion control, distributed control systems, and complicated networking. Thus, smart PLCs provide several advantages over traditional relay-based control systems, including higher reliability, increased flexibility, cheaper cost, communication capabilities, faster reaction time, and simplicity of troubleshooting.

The significance of PLCs is their ease of programming using ladder diagrams for control, and this thesis is primarily motivated by industrial applications. The entire implementation process is carried out in Delta type and conforms with Software (WPL Soft for "Windows Version 10"). MASTER-K120S series is exceptionally small, adaptable to a broad variety of applications, and equipped with the best characteristics. A ladder diagram has been constructed using the graphical user interface to connect with the smart PLC's CPU. The Delta PLC's input-output ports configure the input-output ports of a panel and connect an external relay operation. The control loop is a repeated cycle in which the PLC reads inputs, solves the ladder logic, and then changes the outputs. Following the storage of the input values in memory, the ladder logic is scanned using the stored values rather than the current values. This is done to avoid logic problems when the ladder logic scan's inputs change. The outputs will be scanned when the ladder logic scan is complete (the output values will be changed). Following that, the system returns to do a check, and the loop is repeated forever. As a result, the working environment will be improved.

CONCLUSION

During the working in this project, it had been noted several points can be concluded as

- The developments of the electrical boards by using smart PLC is very useful for controlling the system devices.
- The performance of the system in enhanced by using smart PLC.
- The process of the PST is controlled efficiently and economically by using smart PLC and the system in working now with efficient manner.
- The size of the electrical board to be reduced by 62.5% comparing to old one.
- Building a computer program that is useful in operating 16 number of PST.
- Reduce maintenance costs to 70% (Current drawing is limited to 70% of the old board since the relays, timers, wires, and other control components are reduced.
- The system maintenance is implemented easily with low manpower, short term around time which leads to improved reliability, downsizing and standardization with maintainability.

I. Appendix (Old wiring diagrams)

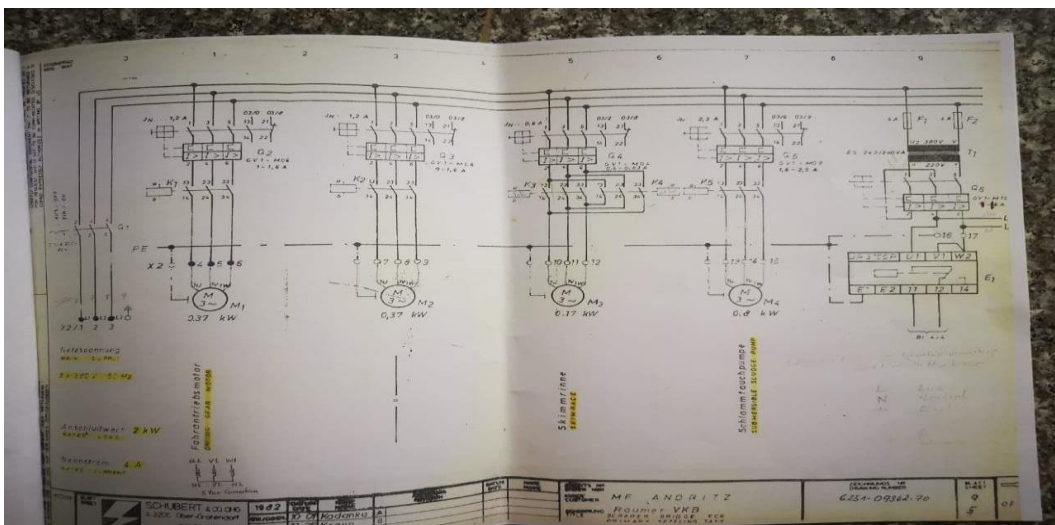

Figure (11) old control wiring diagram Of PST control system

The wiring diagrams in figure (11) were studied thoroughly by knowing a number of limit switch ,coil ,inputs , outputs , counters, and number of timers (ON Delay, OFF Delay) in the northern Rustumiya project plans for the purpose of converting them into components of smart PLC. The control strategy was

extracted from the experience of operators and engineers of the site. Henceforth, allover system was built from the perspective of hardware and software.

ETHICAL DECLARATION

Conflict of interest: No declaration required. **Financing:** No reporting required. **Peer review:** Double anonymous peer review.

REFERENCES

- [1] L V. Godase, “ Smart Energy Management in Manufacturing Plants Using PLC and SCADA” Advance Research in Power Electronics and Devices Vol. 2, Issue 2 pp:14-24, August, 2025.
- [2] A. Hendra, I. Hernadewita and Y. Rizal "Assembly Programmable Logic Control (PLC) in the Rotary Dryer Machine for Processing Waste Liquid System," *Applied Mechanics and Materials*, vol. 842, pp. 319-323, 2016.
- [3] M. Antonio , E. Alphonsus "A review on the applications of programmable logic controllers (PLCs)," *Renewable and Sustainable Energy Reviews* 60 , p. 1185–1205, 2018.
- [4] M. Lashin " Logical Design of Industrial Automation (PLC)," *International Journal of Computer Science, Engineering and Information Technology (IJCEIT)*, Vols. 4,No. 1, , no. 1, February 2014.
- [5] N. Nise” Logical Design of Industrial Automation”, Sixth ed., Pomona : California State Polytechnic University, 2011.
- [6] F. Petruzella“Logical Design of Industrial Automation”, Fourth ed., McGraw-Hill , 2011.
- [7] K. Hassan Kaittan* , S. Jasim Mohammed”PLC-SCADA Automation of Inlet Wastewater Treatment Processes: Design, Implementation, and Evaluation”*Journal Européen des Systèmes Automatisés*Vol.57, No.3, June, pp.787-796, 2
- [9] A. Thomas, U. Mishra,” Effect of the wastewater treatment system and Industry 4.0 implementation for a sustainable tyre production industry”. Alex. Engineering Journal, Vol. 115, 94-11, 2025.
- [10] M. Patziger, F. W. Günthert, N. Jardin, H. Kainz and J. Londong, "On the design and operation of primary settling tanks in state of the art wastewater treatment and water resources recovery," *Water Science & Technology* , 2016.
- [11] J. B. Snape, I. J. Dunn, J. Ingham and J. E. Pfenosi, Dynamics of Environmental Bioprocesses Modelling and Simulation, Printed on acid-free and low-chlorine paper, 1995.
- [12] G. Crini and E. Lichtfouse, "Advantages and disadvantages of techniques used for wastewater treatment," *Environmental Chemistry Letters* , p. 145–155, 2019.
- [13] G. M. Gonza ´lez, H. L. Molina, D. T. Lo ´pez, F. R. Rodr ´guez, , J. L. Navarrete-Bolan ˜os and H. Jime ´nez-Islas, "Approximate Method for Designing a Primary Settling Tank for Wastewater Treatment," *Ind. Eng. Chem* , vol. 48, no. 16, p. 7842–7846, 2009 .
- [14] M. J. Smet , J. M. Pascual and A. Trapote , "Model of Suspended Solids Removal in the Primary Sedimentation Tanks for the Treatment of Urban Wastewater," *Water*, vol. 9, no. 448, 2017.
- [15] S. V. Sastry, B. S. Rao and K. Nahata, "Study of Parameters Before And After Treatment of Municipal Waste Water From An UrbanTown," *Global Journal of Applied Environmental Sciences*, vol. 3, no. 1, pp. 41-48, 2013.
- [16] P. Krupa , D. Limon and T. Alamo, "Implementation of Model Predictive Control in Programmable Logic Controllers," *IEEE Logical Design of Industrial Automation*, 26 May 2020.
- [17] L. Kumar, R. Jetley and A. Sureka, " Source Code Metrics for Programmable Logic Controller (PLC) Ladder Diagram (LD) Visual Programming Language," *International Workshop on Emerging Trends in Software Metrics*, 2016.
- [18] I. C.Febaide, and A. Enughwure” Automation of Water Pump Station of Kurutie Community using Programmable Logic Controller (PLC)”,Delta, Delta Programmable Logic Controller DVP Series, 2023.
- [19] G. Nikolakopoulos”Logical Design of Industrial Automation” Lecture Notes of Industrial Automation, Lulea University of Technology,Department of Electrical, Control Systems and Space Technology, Spring, 2013.
- [20]